

Installation and Care Instructions

2" Horizontal Aluminum Blinds

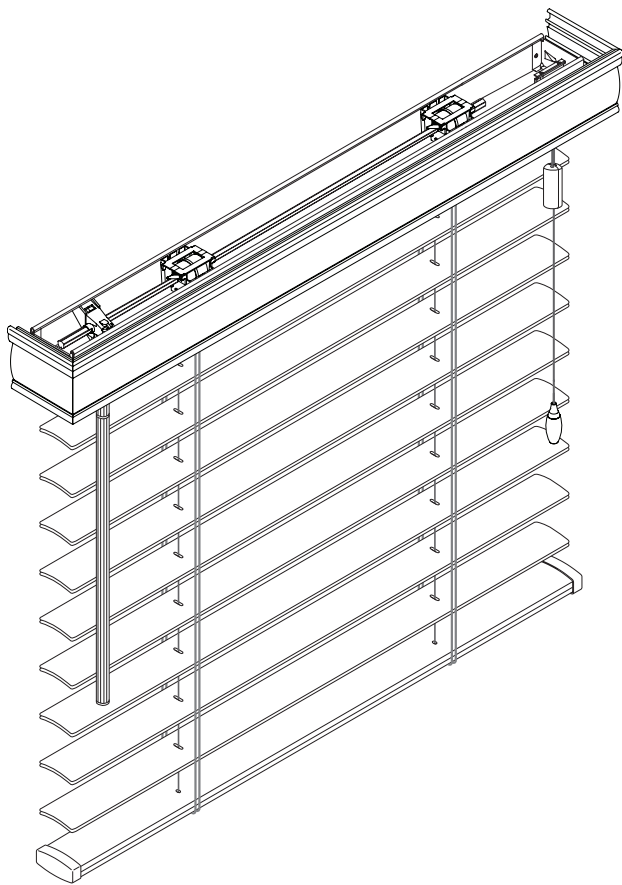

MagnaView™ Tilt Feature

HunterDouglas

CONTENTS

Getting Started	1
Mount the Installation Brackets	2
Install the Blind	4
Complete the Installation	6
Operate the Blind	8
Troubleshooting Procedures	9
Care and Cleaning	10
Child Safety	11

Thank you for your purchase. Your new blinds have been custom built for you from the highest quality materials. Properly installed, they will provide you with a lifetime of beauty and trouble-free performance. **Before installing or operating your new blinds, please review these instructions thoroughly to acquaint yourself with all of the procedures.**

What You Will Need to Install Your Blind

The following tools are required:

- Measuring tape
- Pencil
- Power drill, drill bits, 1/4" hex driver
- Carpenter's level
- Flat blade and Phillips screwdrivers

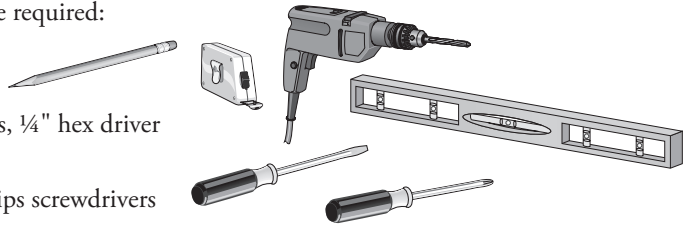

You will also need appropriate fasteners for your specific mounting surface:

Mounting Surface	Type of Fastener
Drywall, Plaster	Wall Anchors, Expansion Bolts (Not Provided)
Metal	Sheet Metal Screws (Not Provided)
Wood	No. 6 Hex Head Screws (Provided)

**For questions or assistance, you may call our
 Customer Information Center at 1-888-501-8364
 7:00 AM to 4:30 PM MST, Mon.-Fri.
 Visit our Web site at hunterdouglas.com**

INSTALLATION INSTRUCTIONS

GETTING STARTED

Check Contents of Your Order

- Remove the blind from the package. Keep the packaging until the blind operates to your satisfaction.
- Check the diagram below to make sure you have all the necessary parts.
- Contents of your hardware package may vary depending upon mounting options chosen and whether intermediate brackets are needed.

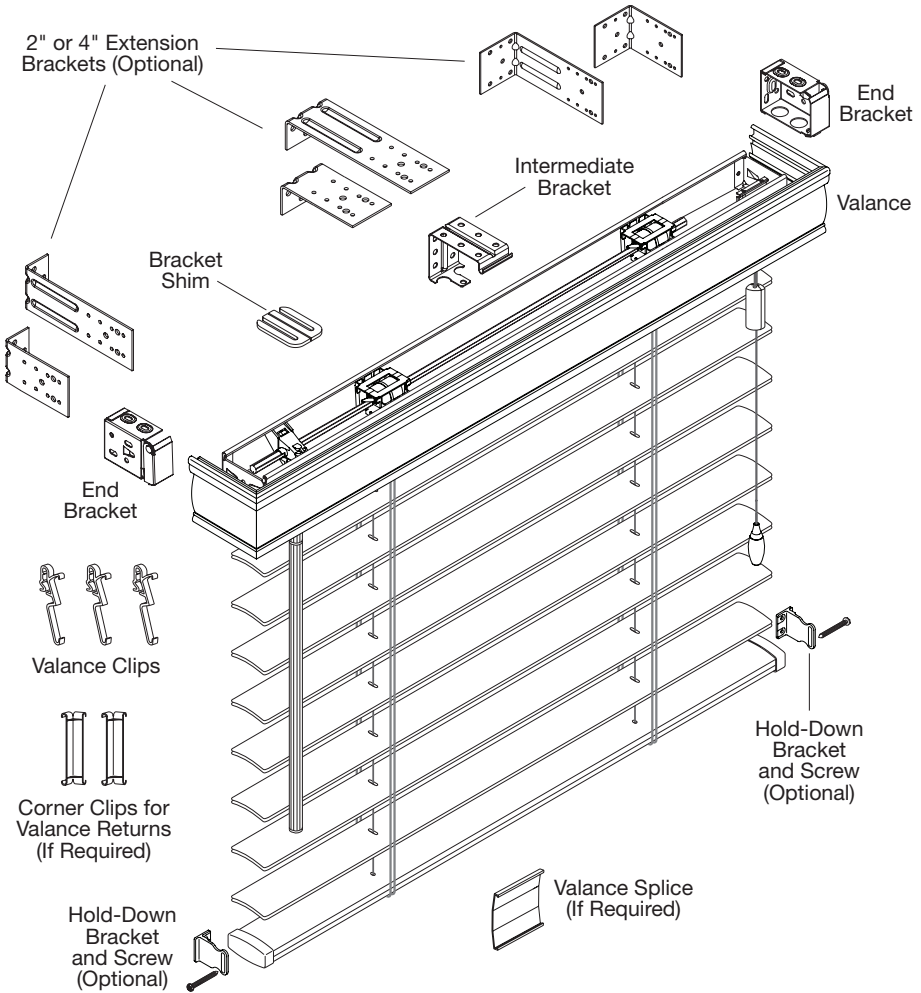

MOUNT THE INSTALLATION BRACKETS

Mounting Options

The installation brackets may be *inside mounted*, *outside mounted* or *ceiling mounted*. In all cases, level mounting is essential.

- With inside mounts and ceiling mounts, use a carpenter's level to check that the mounting surface is level. Shim the brackets, if necessary.
- With outside mounts, the tops of the brackets must be level and aligned at the same height.
- With wider blinds, intermediate brackets are required for both inside and outside mounts (see chart).

Width of Blind	Intermediate Brackets
Up to 72"	0
72 $\frac{1}{8}$ " - 96"	1
96 $\frac{1}{8}$ " - 122"	2

Inside Mount and Ceiling Mount Applications

Attach End Brackets

With inside mounts, attach the two end brackets flush against the sides of the window casement.

- Side mount the brackets with one screw through a side hole and one screw through a top hole, as shown below left.
- Top mount the brackets with screws through the two top holes, as shown below right.
- If limited mounting depth is available, the bracket may be mounted with two screws through diagonal side holes.

A casement depth of 3 $\frac{1}{2}$ " is required to fully recess the blind inside the opening. A minimum depth of 1 $\frac{1}{8}$ " is required for bracket attachment.

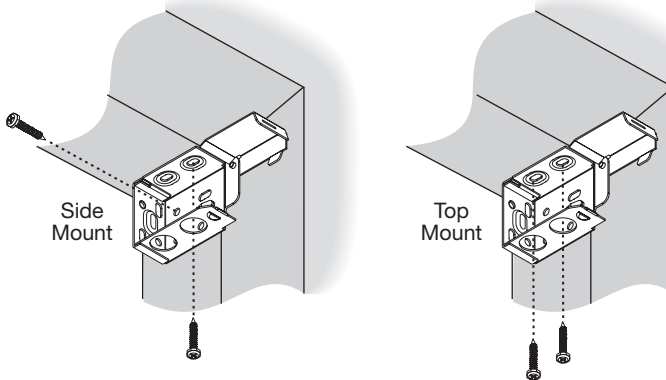

With ceiling mounts, the brackets are top mounted with screws through the two top holes. You may need to add a bracket shim to allow clearance for the valance clips.

Bracket Shims

In addition to adding top clearance for ceiling mounts, bracket shims may be used whenever the mounting surface is not flat enough to mount the blind correctly.

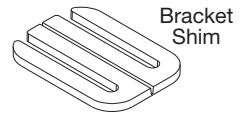

Intermediate Brackets (If Required)

Evenly space the intermediate bracket(s) between the two end brackets. A minimum depth of 1½" is required for bracket attachment.

- Adjust spacing if needed to avoid interference with internal headrail mechanisms.
- Attach with two screws through diagonal holes.
- The backs of the end brackets and intermediate bracket(s) must align.

Note: With ceiling mounts, you may need to add a bracket shim to allow clearance for the valance clips.

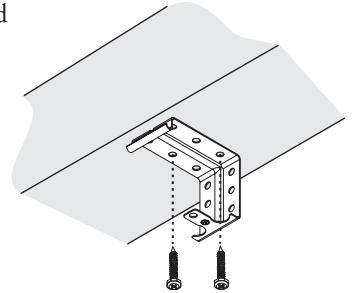

Outside Mount Applications

A flat vertical surface at least 1¾" high is required for bracket attachment.

Mark End Bracket Locations

- Mark where the ends of the headrail will be located.
- Either hold the headrail up to the mounting surface or measure the headrail and mark its width.
- Then mark ¼" to the outside of the headrail end marks.

Measure and Mark ¼" Out from Ends of Headrail

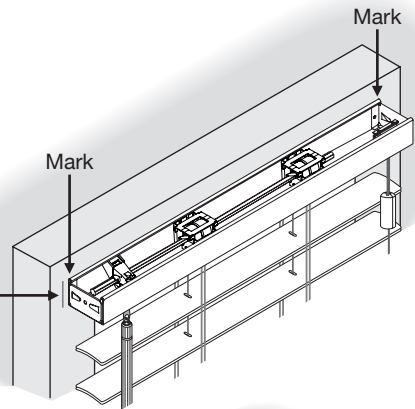

Attach End Brackets

- Align the outside edge of each bracket with the outer marks.
- The tops of the brackets must be aligned at the same height.
- Attach the brackets with two screws through diagonal rear holes.

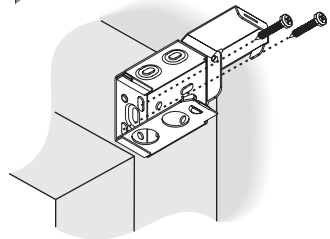

Intermediate Brackets (If Required)

Evenly space the intermediate bracket(s) between the end brackets.

- Adjust spacing if needed to avoid interference with internal headrail mechanisms.
- The top of each intermediate bracket must align with the tops of the end brackets.
- Attach the bracket(s) with two screws through diagonal holes.

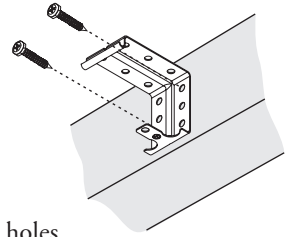

Extension Brackets (Optional)

Attach 2" or 4" extension brackets to the mounting surface in the same locations where the end brackets and intermediate brackets would be attached.

- Align and level extension brackets with a carpenter's level.
- Use two screws to mount each extension bracket.
- Attach the installation brackets and intermediate brackets to the extension brackets using the screws and nuts provided, as shown below.

End Bracket with 2" Extension Bracket

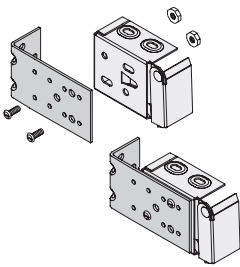

Intermediate Bracket with 2" Extension Bracket

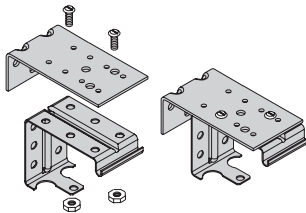

End and Intermediate Brackets with 4" Extension Bracket

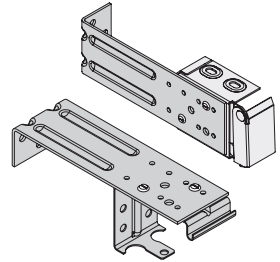

INSTALL THE BLIND

Valance Clips

- Attach valance clips 2" from each end of the headrail.
- Space additional clip(s) evenly between the two end clips so that the valance clips are no more than 36" apart.
- Do not place the valance clips where they could interfere with any working parts.
- If desired, the valance may be positioned $\frac{1}{4}$ " higher by raising the valance clips one notch up, as shown at right.

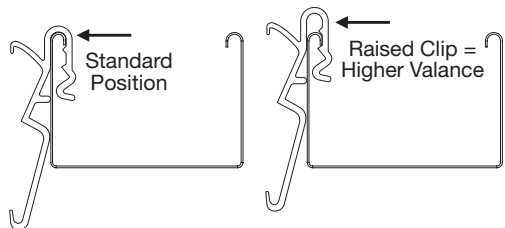

Mount the Headrail

- Tilt headrail so that its back lip slides under the front lip of the end brackets and intermediate bracket(s).
- Push headrail against the back of the end brackets.
- Check that the front lip of the intermediate bracket(s) is under the front lip of the headrail.

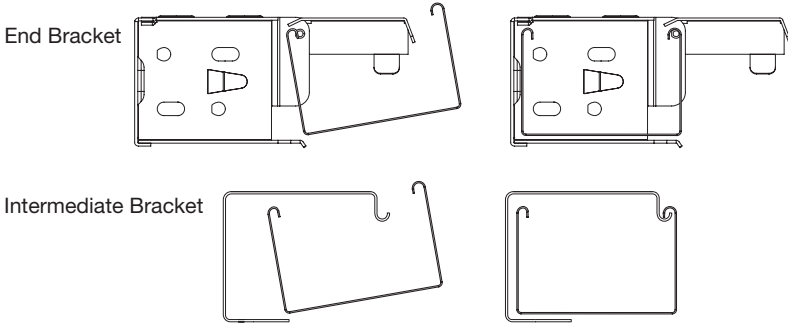

Adjust Headrail Tightness

- If the headrail is loose in the end brackets, bend the tabs on the brackets outward. The tabs may also be bent inward if the headrail is difficult to install into the end brackets.
- If your headrail end brackets do not have adjustable tabs, bend the tabs on the headrail end locks to adjust headrail tightness.

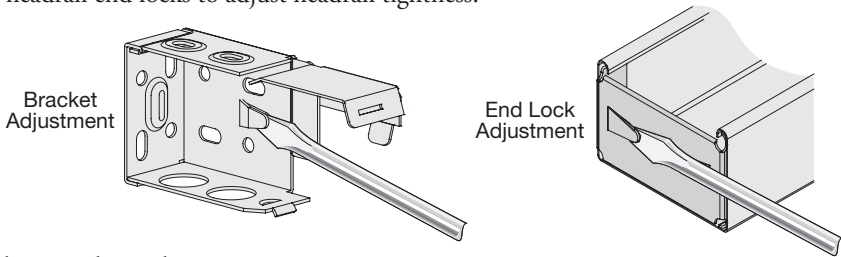

Close End Brackets

- Push the cover down until it snaps over the locking tab on the bottom of the bracket.

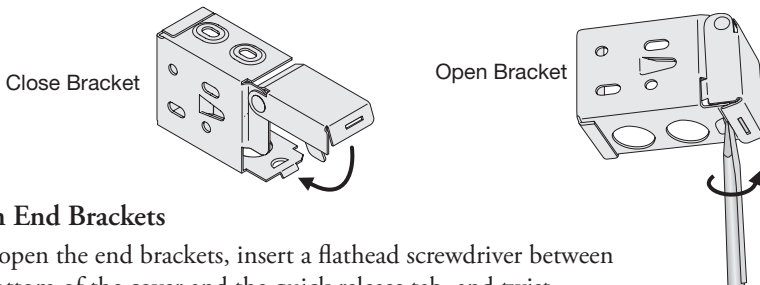

Open End Brackets

- To open the end brackets, insert a flathead screwdriver between the bottom of the cover and the quick release tab, and twist.
- You can also push up on the bottom of the bracket to release the locking tab.

COMPLETE THE INSTALLATION

Attach the Wand (If Ordered)

- Pull the plastic sleeve from the top of the wand and insert it over the metal shaft.
- Insert the hook on the wand through the hole in the metal shaft.
- Slide the plastic sleeve down over the hook until firmly seated.
- Test the wand tilter. Approximately six revolutions of the wand should tilt the slats from fully closed up to fully closed down.

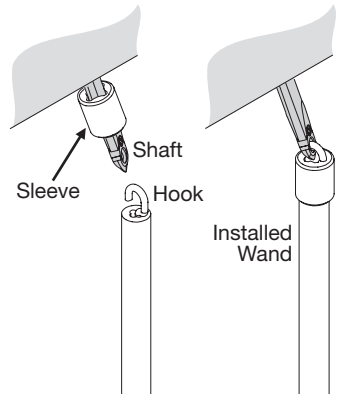

Attach the Valance Returns, If Necessary

If the valance came with returns and they are not already attached, connect the returns to the valance using the corner clips provided.

- The notches on the rear of the valance and returns fit into the grooves of the corner clips.
- Slide one end of each clip onto the rear of the valance until the center of the clip aligns with the edge of the miter cut at each end.
- Slide a return onto each corner clip until its miter is flush against the miter on the valance.

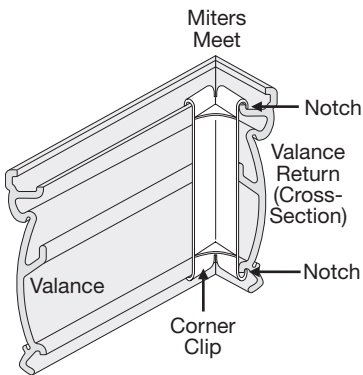

Standard Modern Precious Metals®
Valance

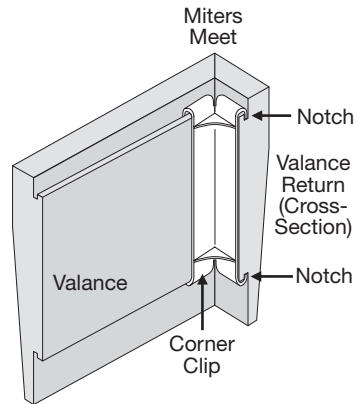

Alustra® Modern Precious Metals
Valance

Attach the Valance

- Tilt the valance to insert its bottom notch into the bottom part of the valance clip.
- Pulling the valance slightly downward, insert the top notch of the valance into the clip, as shown.
- To remove the valance, gently pull the valance downward to release it from the top of the valance clips. Rotate the top of the valance toward you. Lift up the valance to release it from the bottom of the valance clips.

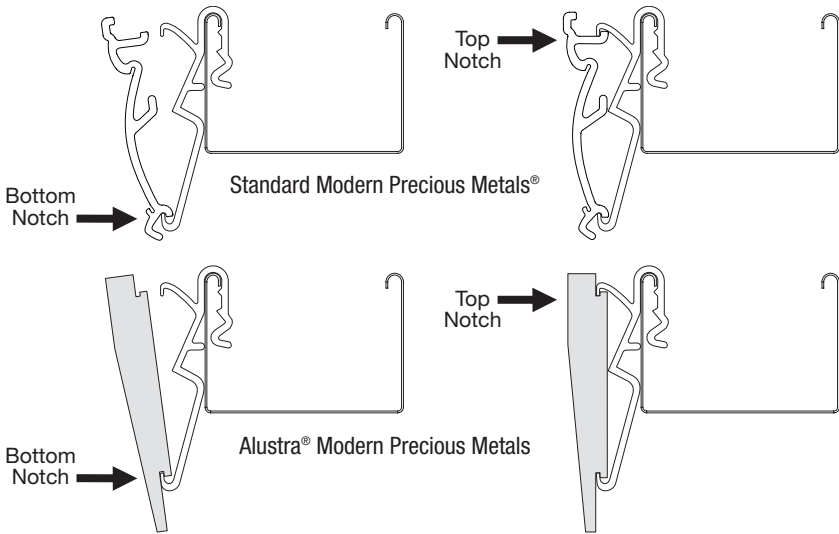

Attach Hold-Down Brackets (Optional)

Hold-down brackets may only be used with outside-mounted blinds.

- Fully lower the blind and completely open the slats.
- Mount the hold-down brackets to the outside mounting surface with the bottom of the slot aligned with the center of the perforated hole on the bottom rail end caps. (With wood bottom rails, drill a hole in the center of the rail and align with it.)
- Screw the washer head Philips screws through the slot in the bracket and into the perforated hole (or drilled hole), leaving enough gap for the screw to slide freely up and down the slot.

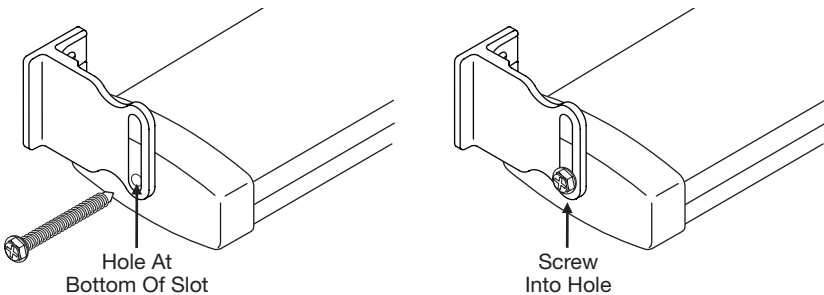

OPERATE THE BLIND

Tilting the Slats

After installation, tilt the slats from fully closed in one direction to fully closed in the other. **Repeat three or four times to work all components in place.**

- **Wand tilt:** Rotate the wand to tilt the slats to the desired angle. For optimal closure, an extra twist of the wand is required to close the slats tightly.
- **Cord tilt:** The two cords with individual tassels are for tilting the slats. Each cord tilts the slats in an alternate direction.

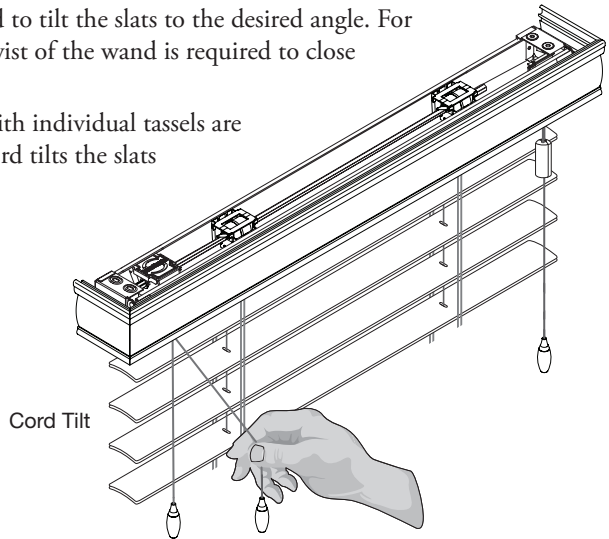

Raising and Lowering the Blind

Important: Whenever raising or lowering the blind, the slats must be in the open position.

- Pull the single cord down and toward the center to raise and lower.
- Hold the cord to the outside to lock the blind in position.

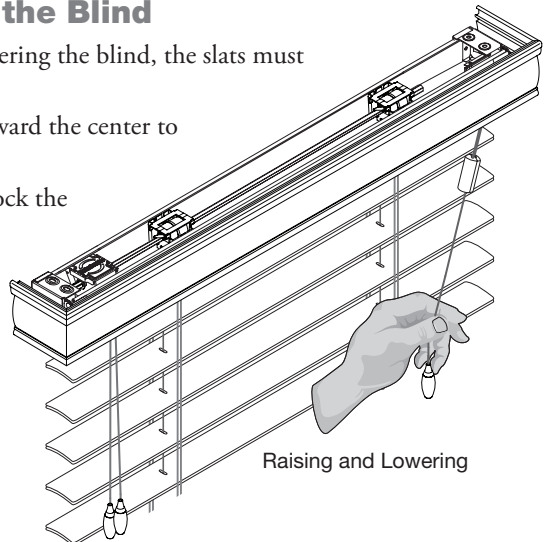

TROUBLESHOOTING

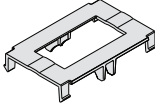
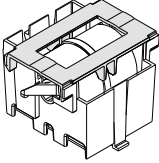
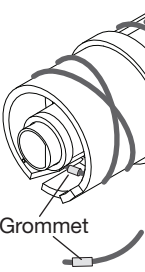
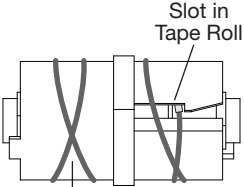
PROBLEM	SOLUTION
The blind does not raise and lower evenly.	Check inside the headrail. Make sure no obstructions keep the mechanism from turning. Check that lift cords are not pinched or tangled.
The lift cord is wrapped around the ladder tape.	Remove the plastic cap on the bottom of the blind that covers the cord rout hole. Untie knot in lift cord and re-thread. Re-tie the knot and replace cap.
Slats are not closing evenly. – or – The blind does not tilt.	<p>Check that tape roll support covers are installed correctly onto the tape rolls and tape roll supports. If covers are not installed correctly, tape strings could become lodged and blind will not operate as designed.</p> <div style="display: flex; justify-content: space-around; align-items: center;"> <div style="text-align: center;">  <p>Tape Roll Support Cover</p> </div> <div style="text-align: center;">  <p>Cover on Tape Roll and Tape Roll Support</p> </div> </div> <p>If grommet on tape string has come out of the slot in the tape roll, place grommet back into the slot.</p> <div style="display: flex; justify-content: space-around; align-items: center;"> <div style="text-align: center;">  <p>Grommet</p> </div> <div style="text-align: center;">  <p>Slot in Tape Roll</p> <p>Crossing Pattern Should Look Like This</p> </div> </div> <p>If necessary, re-position tape string on tape roll to the correct crossing pattern.</p> <p>If blind does not tilt: Check to be sure the tiltrod is fully inserted into the tilt gear.</p>

CARE AND CLEANING

Blinds should be cleaned regularly to keep them looking new.

- Dust regularly. Use a soft clean cloth, chemically-treated dust cloth or dusting mitt. Lower the blind to its full length, tilt the slats almost all the way down and dust. Then tilt the slats almost all the way up and dust. (Not closing the slats all the way allows dusting where the slats overlap.)
- Blinds may also be vacuumed. Use the brush attachment and tilt the slats up and down as described for dusting.
- Another way to clean blinds is simply by wiping them with a soft, damp cloth.
- Wash the slats only using a non-abrasive mild detergent solution. Allow to air dry to preserve the dust repellent properties of the slats.
- For a more thorough cleaning, metal bottom rails and slats may be immersed in a bathtub. Do not immerse headrails or wood bottom rails. Bathtub cleaning is not recommended for blinds with wide tapes.
- The stained wood components of Alustra® Modern Precious Metals® blinds, like wood furniture, should be treated periodically with lemon oil or other wood preservative to protect their finish and enhance their luster.
- Hunter Douglas does not recommend ultrasonic cleaning of Alustra Modern Precious Metals blinds.

A NOTE ABOUT WOOD PRODUCTS

The bottom rail and valance of Alustra Modern Precious Metals blinds are true wood products, made from 100% hardwood. There will be variations in color, grain and texture that are characteristic of all woods. These variations will be especially visible in blinds with light color stains. The variations are normal and natural, and are considered acceptable quality.



! WARNING

For more safety information call 1-888-501-8364 in the U.S. or 1-866-662-0666 in Canada.

Young children can **STRANGLE** in cord loops and in the loop above the cord stop. They can also wrap cords around their necks and **STRANGLE**. In addition, inner cords can pull out to form a loop, which can **STRANGLE** a young child.



- Always keep cords out of children's reach.
- Move cribs, playpens and other furniture away from cords.
Children can climb furniture to get to cords.
- Do not tie cords together. Make sure cords do not twist together and create a loop.

Cord Stop

- This component acts as a stopper to prevent inner cords from being pulled through the blind, which can pose the risk of entanglement.
- It is also designed to break apart under significant pressure, which may lessen the risk of entanglement in the top lift cords.

Reassembly of Cord Stop

- Reinsert any loose cords into the top notches of the cord stop. There is a notch on each side.
- Line up the two halves of the cord stop and snap the pieces back together.

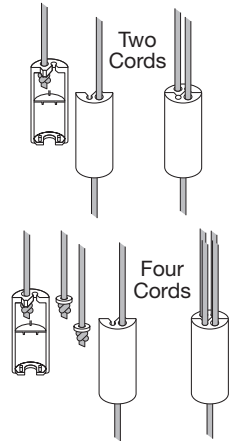

Cord Cleats

Hunter Douglas offers cord cleats and we recommend their use.

- Attach two cord cleats 6" to 12" apart at a height where they will be out of the reach of children. Take into account that a child may stand on furniture attempting to reach the cords.
- Be sure the cleats are firmly secured.
- Once the cleats are attached, wrap excess cord around them after each use of the blind.



LIFETIME GUARANTEE

The Hunter Douglas® Lifetime Guarantee is an expression of our desire to provide a thoroughly satisfying experience when selecting, purchasing and living with your window fashion products. If you are not thoroughly satisfied, simply contact Hunter Douglas at (888) 501-8364 or visit hunterdouglas.com. In support of this policy of consumer satisfaction, we offer our Lifetime Limited Warranty as described below.

COVERED

BY A LIFETIME LIMITED WARRANTY

- Hunter Douglas window fashion products are covered for defects in materials, workmanship or failure to operate for as long as the original retail purchaser owns the product (unless shorter periods are provided below).
- All internal mechanisms.
- Components and brackets.
- Fabric delamination.
- Operational cords for a full 7 years from the date of purchase.
- Repairs and/or replacements will be made with like or similar parts or products.
- Hunter Douglas motorization components are covered for 5 years from the date of purchase.

NOT COVERED

BY A LIFETIME LIMITED WARRANTY

- Any conditions caused by normal wear and tear.
- Abuse, accidents, misuse or alterations to the product.
- Exposure to the elements (sun damage, wind, water/moisture) and discoloration or fading over time.
- Failure to follow our instructions with respect to measurement, proper installation, cleaning or maintenance.
- Shipping charges, cost of removal and reinstallation.

Hunter Douglas (or its licensed fabricator/distributor) will repair or replace the window fashion product or components found to be defective.

TO OBTAIN WARRANTY SERVICE

1. Contact your original dealer (place of purchase) for warranty assistance.
2. Visit hunterdouglas.com for additional warranty information, frequently asked questions and access to service locations.
3. Contact Hunter Douglas at (888) 501-8364 for technical support, certain parts free of charge, for assistance in obtaining warranty service or for further explanation of our warranty.

NOTE: In no event shall Hunter Douglas or its licensed fabricators/distributors be liable or responsible for incidental or consequential damages or for any other indirect damage, loss, cost or expense. Some states do not allow the exclusion or limitation of incidental or consequential damages, so the above exclusion or limitation may not apply to you. This warranty gives you specific legal rights, and you may also have other rights which vary from state to state.

Different warranty periods and terms apply for commercial products and applications.



HunterDouglas

hunterdouglas.com



© 2010 Hunter Douglas Inc. ® Registered trademark of Hunter Douglas Inc. ™ Trademark of Hunter Douglas Inc. The GREENGUARD INDOOR AIR QUALITY CERTIFIED mark is a registered certification mark used under license through the GREENGUARD Environmental Institute.

